

VOLVO PENTA

VOLVO PENTA INBOARD DIESEL

D13-800/900/1000

12.8 liter, in-line 6 cylinder



Technical Data

Engine designation	D13-800	D13-900	D13-1000
No. of cylinders and configuration	in-line 6	in-line 6	in-line 6
Method of operation	4-stroke, direct-injected, turbocharged diesel engine with charge air cooler		
Bore/stroke, mm (in.)	131/158 (5.16/6.22)	131/158 (5.16/6.22)	131/158 (5.16/6.22)
Displacement, l (in ³)	12.78 (779.7)	12.78 (779.7)	12.78 (779.7)
Compression ratio	17.1:1	17.1:1	17.1:1
Dry weight bobtail, kg (lb)	1625 (3583)	1630 (3594)	1635 (3605)
Crankshaft power, kW (hp) @2300 rpm	588 (800)	662 (900)	735 (1000)
Max. torque, Nm (lbf.ft) @1800 rpm	3029 (2234)	3304 (2437)	3528 (2602)
Emission compliance	IMO NOx, EU RCD Stage II, US EPA Tier 3, China 2		
Rating	R4	R5	R5
Recommended fuel to conform to	ASTM-D975 1-D & 2-D, EN 590 or JIS KK 2204		
Flywheel housing/SAE size	14"/SAE1	14"/SAE1	14"/SAE1

Technical data according to ISO 8665. With fuel having an LHV of 42700 kJ/kg and density of 840 g/liter at 15 °C (60 °F). Merchant fuel may differ from this specification which will influence engine power output and fuel consumption.

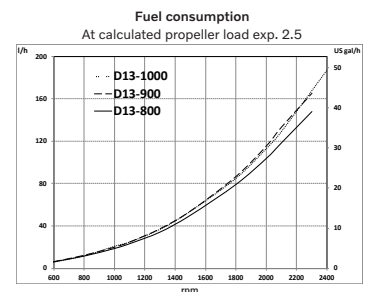
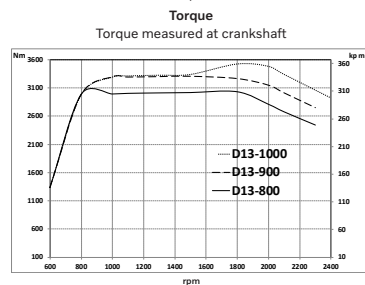
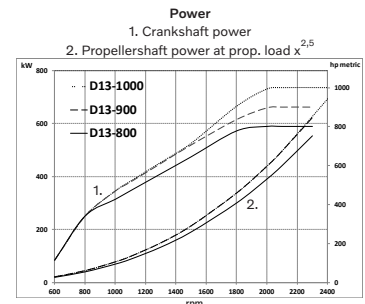

D13-800/900/1000

12.8 liter, in-line 6 cylinder

Technical description

Engine and block

- Cylinder block made of cast iron
- One-piece cast-iron cylinder head
- Ladder frame fitted to engine block
- Replaceable wet cylinder liners and valve seats/guides
- Drop forged crankshaft with induction hardened bearing surfaces and fillets with seven main bearings
- Four-valve-per-cylinder layout with overhead camshaft and center position of unit injectors
- Each cylinder features cross-flow inlet and exhaust ducts
- Monotherm steel pistons
- Rear-end transmission

Engine mounting

- Flexible engine mounting

Lubrication system

- Integrated oil cooler in cylinder block
- Rear positioned twin full flow oil filter of spin-on type and by-pass filter

Fuel system

- Electronic high pressure unit injectors
- Gear-driven fuel pump and injection timing
- Electronically controlled central processing system (EMS – Engine Management System)
- Single fine fuel filter of spin-on type

Air inlet and exhaust system

- Twin entry turbo technology with freshwater-cooled charge air cooler
- Air filter with replaceable inserts
- Wet exhaust elbow (option)
- Loss of sea water alarm

Cooling system

- Seawater-cooled plate heat exchanger
- Coolant system prepared for hot water outlet
- Easily accessible seawater pump in rear end of flywheel housing

Electrical system

- 24V/110A plus an optional extra 12V/115A alternator



Electronic Vessel Control (EVC)

- Fully integrates the engines, electronics and the unique set of EVC features; Joystick Docking (available for twin engine installations), Glass Cockpit and more

Gear box

- ZF500-1A-E and ZF500-11V-E, with low speed as option, electronically shifted
- ZF-400A, with low speed as standard, electronically shifted
- Connection kits for Twin disc available

Dimensions D13-1000 with ZF400A

Not for installation

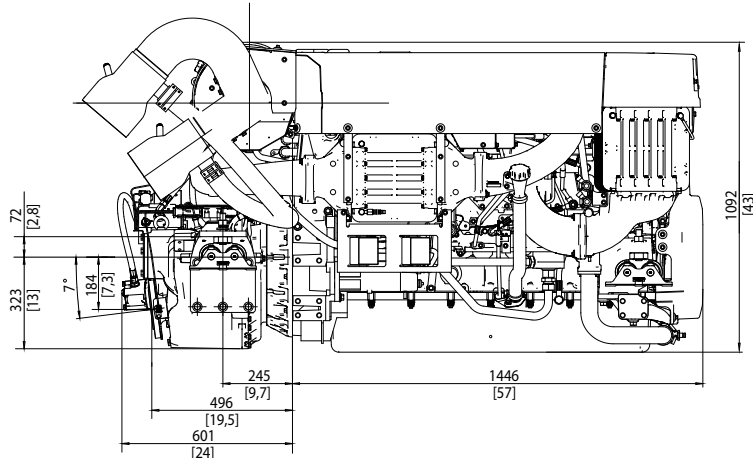
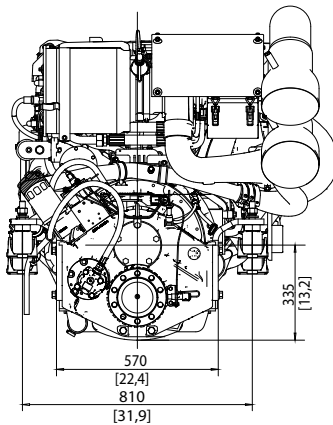

Not all models, standard equipment and accessories are available in all countries. All specifications are subject to change without notice. The engine illustrated may not be entirely identical to production standard engines.

Contact your local Volvo Penta dealer for more information regarding Volvo Penta engines and optional equipment/accessories or visit www.volvopenta.com



AB Volvo Penta

SE-405 08 Göteborg, Sweden
www.volvopenta.com

English 07-2024 © 2024 AB Volvo Penta.

JOHNSON & TOWERS
2021 Briggs Road
Mt. Laurel, NJ 08054
www.johnsontowers.com

ENGINE SALES
JD Messler
jdmessler@johnsontowers.com
609-605-6528

PARTS & SERVICE
Mike Townsley
mtownsley@indelpower.com
757-374-4104

