

# VOLVO PENTA

## VOLVO PENTA INBOARD DIESEL

# D2-60

2.2 liter, in-line 4 cylinder



### Technical Data

Engine designation	D2-60
Crankshaft power, kW (hp)	44 (60)
Propeller shaft power, kW (hp)	42 (58)
Engine speed, rpm	2700–3000
Displacement, l (in <sup>3</sup> )	2.2 (134.2)
Number of cylinders	4
Bore/stroke, mm (in.)	84/100 (3.31/3.94)
Compression ratio	23.3:1
Dry weight with reverse gear HS25A/MS25, kg (lb)	264/258 (582/569)
Dry weight with saildrive 150S, kg (lb)	264 (582)
Emission compliance	BSO, EU RCD Stage II, US EPA Tier 3
Rating	R5*

Technical data according to ISO 8665. With fuel having an LHV of 42700 kJ/kg and density of 840 g/liter at 15°C (60 °F). Merchant fuel may differ from this specification which will influence engine power output and fuel consumption.

\*RATING 5. For pleasure craft applications, and can be used for high speed planing crafts in commercial applications

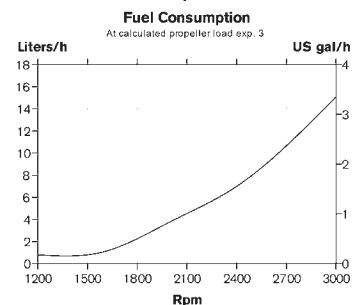
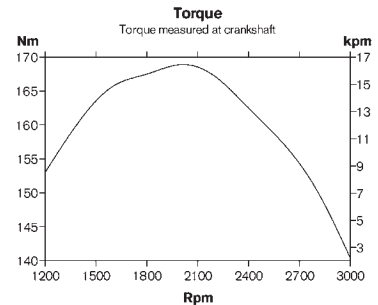
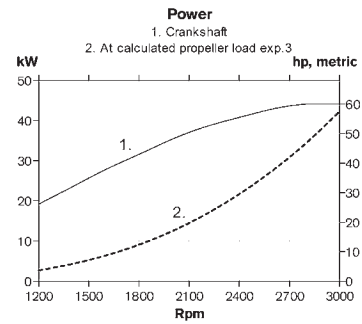

# D2-60

2.2 liter, in-line 4 cylinder

## Technical description

### Engine block and head

- Cylinder block and cylinder head manufactured from high grade cast iron. Crankcase features a rigid tunnel block design.
- Chrome molybdenum forged crankshaft, statically and dynamically balanced with integral counterweights. Pistons are cast from high silicon aluminum, are heat treated and fitted with two cast iron, chromium faced compression rings and a single oil ring.
- Replaceable, hardened valve seats
- Elastic coupling on flywheel

### Engine mounting

- Tuned front and rear cushion-type rubber mounts. Adjustable.

### Lubrication system

- Spin-on fullflow oil filter
- Separate oil scavenger pipe
- Closed circuit crankcase ventilation
- One top and one side oil filling position

### Fuel system

- Flange mounted, cam driven in-line injection pump
- Feed pump with hand primer
- Spin-on type fine fuel filter
- Auxiliary stop button on engine

### Exhaust system

- Freshwater cooled exhaust manifold and seawater cooled exhaust elbow

### Cooling system

- Freshwater cooling system governed by thermostat
- Tubular heat exchanger with integral expansion tank
- Easily accessible sea water pump and impeller

### Electrical system

- 12V corrosion-protected electrical system
- 115A marine alternator
- 24V alternator as option
- Charging regulator with electronic sensor for voltage drop compensation
- Glow plugs for excellent cold starting
- Electric starter motor (2.0 kW output)
- Electrical stop
- Extension cable harness with plug-in connection available in various lengths

### EVC instruments

- Start/stop panel
- Tachometer with alarms and engine hour counter

### Options:

- Separate instruments for:
  - Fuel level
  - Temperature
  - Voltage
- LCD display with multisensor
- NMEA interface presenting engine data on chart plotters

### Choice of transmissions

**HS25A** Hydraulic – drop center with 8° down angled output shaft.

- Ratio 2.29:1/2.29:1 (RH/LH) and 2.71:1/2.71:1 (RH/LH).

**MS25A** Mechanical – drop center with 8° down angled output shaft.

- Ratio 2.23:1/2.74:1 (RH/LH) and 2.74:1/2.74:1 (RH/LH).

**MS25L** Mechanical – drop center with straight output shaft.

- Ratio 2.27:1/2.10:1 (RH/LH) and 2.74:1/2.72:1 (RH/LH).

**S-drive 150S.** The S-drive can be mounted with reverse installation of the engine. Ratio 2.19:1. The drive is also available in an SR version.

### Accessories

- Engine controls and steering systems
- Extra alternator kits
- Battery and battery switches
- Hot water systems
- Separate expansion tanks
- Cooling water seacocks, strainers and hoses
- Exhaust systems and hull fittings
- Fuel systems including filters, pipes etc.
- Pulleys and universal brackets for power take-off (PTO)
- Propeller shaft systems and propellers
- Chemical products – paints, oils, cleaners etc

## Dimensions D2-60/150S/MS25A

Not for installation

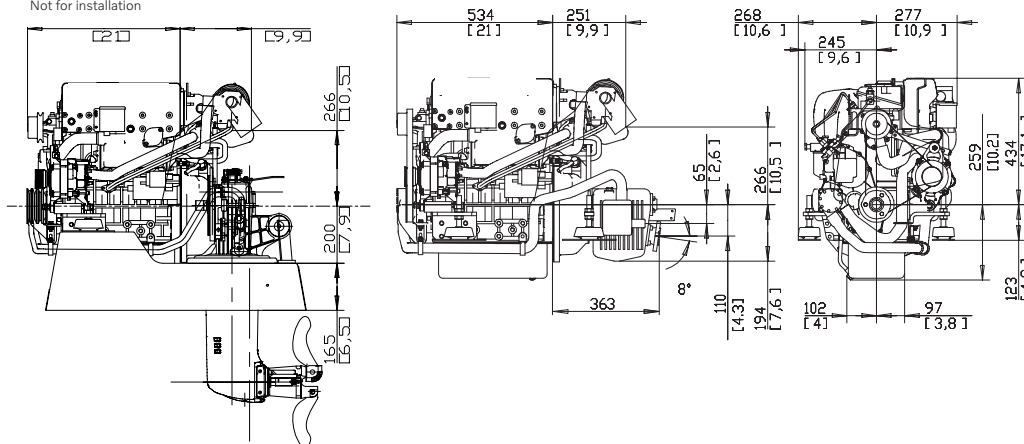

Not all models, standard equipment and accessories are available in all countries. All specifications are subject to change without notice. The engine illustrated may not be entirely identical to production standard engines.

Contact your local Volvo Penta dealer  
for more information regarding Volvo  
Penta engines and optional equipment/  
accessories or visit  
[www.volvopenta.com](http://www.volvopenta.com)



## AB Volvo Penta

SE-405 08 Göteborg, Sweden  
[www.volvopenta.com](http://www.volvopenta.com)

English 11-2022 © 2022 AB Volvo Penta.

JOHNSON & TOWERS  
2021 Briggs Road  
Mt. Laurel, NJ 08054  
[www.johnsontowers.com](http://www.johnsontowers.com)

ENGINE SALES  
JD Messler  
[jdmessler@johnsontowers.com](mailto:jdmessler@johnsontowers.com)  
609-605-6528

PARTS & SERVICE  
Mike Townsley  
[mtownsley@indelpower.com](mailto:mtownsley@indelpower.com)  
757-374-4104



JOHNSON & TOWERS