

## VOLVO PENTA INBOARD DIESEL

# D6-300/340/380

5.5 liter, in-line 6 cylinder



### Technical Data

Product designation	D6-300 I	D6-340 I	D6-380 I
Crankshaft power, kW (hp)	221 (300)	250 (340)	280 (380)
Propeller shaft power, kW (hp)	212 (289)	241 (327)	269 (366)
Engine speed, rpm	3300	3400	3500
Engine displacement, l (in <sup>3</sup> )	5.50 (335.6)	5.50 (335.6)	5.50 (335.6)
Engine configuration	in-line 6	in-line 6	in-line 6
Aspiration	turbo, after cooler	turbo, after cooler	turbo, after cooler
Rating	R4*	R4*	R4*
Dry weight with HS68IV, kg (lb)	695 (1532)	N/A	N/A
Dry weight with HS68A, kg (lb)	665 (1466)	N/A	N/A
Dry weight with HS85IV, kg (lb)	720 (1587)	720 (1587)	720 (1587)
Dry weight with HS85A, kg (lb)	690 (1521)	690 (1521)	690 (1521)
Ratio HS68IV	1.992	N/A	N/A
Ratio HS68A	2.037 - 2.52	N/A	N/A
Ratio HS85IV	2.008 - 2.493	2.008 - 2.493	2.008 - 2.493
Ratio HS85A	1.962 - 2.500	1.962 - 2.500	1.962 - 2.500
Voltage	12V or 24V	12V or 24V	12V or 24V
Emission compliance	IMO NOx, EU RCD Stage II, US EPA Tier 3		
Flywheel / flywheel housing	SAE10 / SAE4	SAE10 / SAE4	SAE10 / SAE4

Technical data according to ISO 8665. With fuel having an LHV of 42700 kJ/kg and density of 840 g/liter at 15 °C (60 °F). Merchant fuel may differ from this specification which will influence engine power output and fuel consumption.

\*RATING 4. For light planing craft in commercial operation.

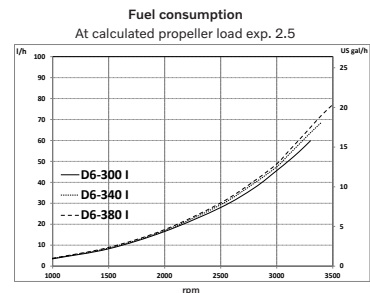
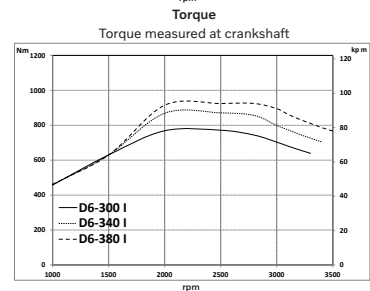
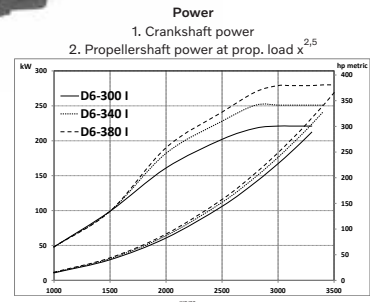

# D6-300/340/380

5.5 liter, in-line 6 cylinder

## Technical description

### Engine block and head

- Cylinder block and cylinder head made of cast iron
- Ladder frame fitted to engine block
- 4-valve technology with hydraulic lash adjusters
- Double overhead camshafts
- Oil-cooled pistons with two compression rings and one oil scraper ring
- Integrated cylinder liners
- Seven bearing crankshaft
- Rear end transmission

### Engine mounting

- Flexible engine mounting

### Lubrication system

- Replaceable separate full-flow and bypass oil filter
- Seawater-cooled tubular oil cooler
- Oil level and oil temperature sensors
- Crankcase oil separator, maintenance free unit

### Fuel system

- Common rail fuel injection system, 2000 bar
- Electronically controlled central processing system (EMS – Engine Management System)

- Fuel pressure sensor that indicates clogging in fuel filters
- Single fine fuel filter of spin-on type, with water separator and water in fuel alarm

### Air inlet and exhaust system

- Air filter with replaceable insert
- Crankcase gases vented into the air inlet
- Exhaust elbow or exhaust riser
- Turbocharger, freshwater cooled
- Loss of sea water alarm

### Cooling system

- Thermostatically regulated freshwater cooling
- Seawater cooled tubular heat exchanger
- Coolant system prepared for hot water outlet
- Seawater impeller pump
- Engine mounted seawater strainer

### Electrical system

- Marine alternator (12V/150A or 24V/80A) prepared for Pulse Width Modulation (PWM)
- Automatic fuses for engine, transmission and EVC
- Auxiliary stop switch in front of engine
- Engine available as 12V or 24V
- Power connections and fuses co-located in one connection box on engine

### Electronic Vessel Control (EVC)

- Fully integrates the engines, electronics and EVC features with Glass Cockpit
- Electronic shift and throttle as standard
- Electronic steering as option in twin installations
- Plug-in connectors
- Low speed control as option
- Joystick option for twin installation
- Autopilot with Joystick Driving as option with twin installation
- Support for Easy Connect app
- Maintenance Assistant with service alert

### Gear box

- Gear box with matched drop center and 8° down angle for compact installation and minimum propeller shaft angle. V-drive available.
- Bevel gears which results in smooth running at all speeds
- Hydraulically operated clutch for smooth shifting
- Electrical shifting performed by electromagnetic valves
- When under sail propeller shaft can rotate 24 hours without engine start
- Seawater cooled oilcooler
- Low speed as option

### Option

- U.S.C.G./MED (SOLAS)

## Dimensions D6-300, D6-340, D6-380 / HS85A

Not for installation

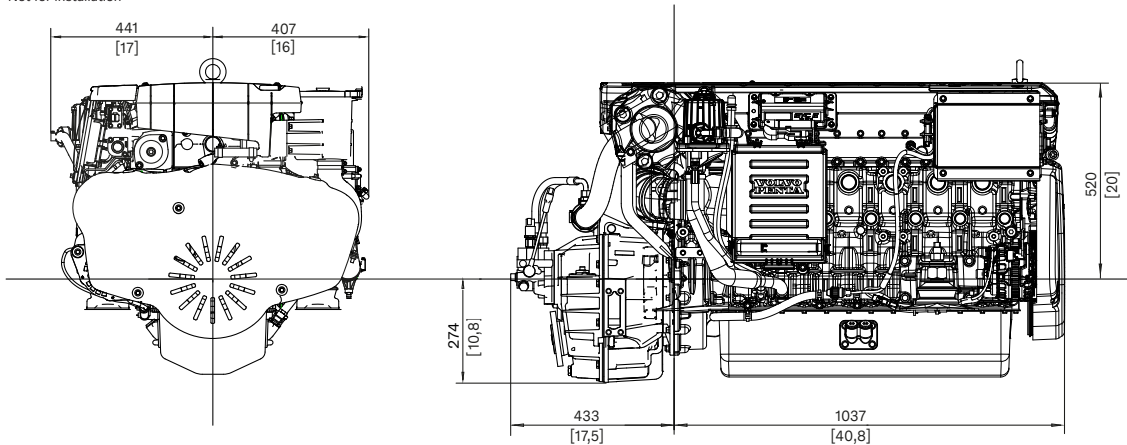

Not all models, standard equipment and accessories are available in all countries. All specifications are subject to change without notice. The engine illustrated may not be entirely identical to production standard engines.

Contact your local Volvo Penta dealer for more information regarding Volvo Penta engines and optional equipment/ accessories or visit [www.volvopenta.com](http://www.volvopenta.com)



### AB Volvo Penta

SE-405 08 Göteborg, Sweden  
[www.volvopenta.com](http://www.volvopenta.com)

English 05-2021 © 2021 AB Volvo Penta.

JOHNSON & TOWERS  
2021 Briggs Road  
Mt. Laurel, NJ 08054  
[www.johnsontowers.com](http://www.johnsontowers.com)

ENGINE SALES  
JD Messler  
[jdmessler@johnsontowers.com](mailto:jdmessler@johnsontowers.com)  
609-605-6528

PARTS & SERVICE  
Mike Townsley  
[mtownsley@indelpower.com](mailto:mtownsley@indelpower.com)  
757-374-4104

